

CILINDROS PARA RACHADORAS

Log splitter cylinders / Vérins pour fendeuses / Holzspalterzylinder

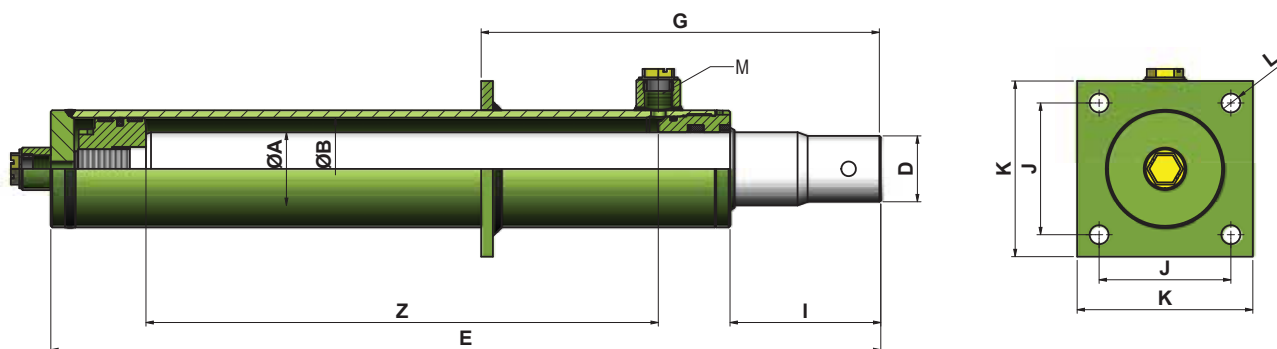
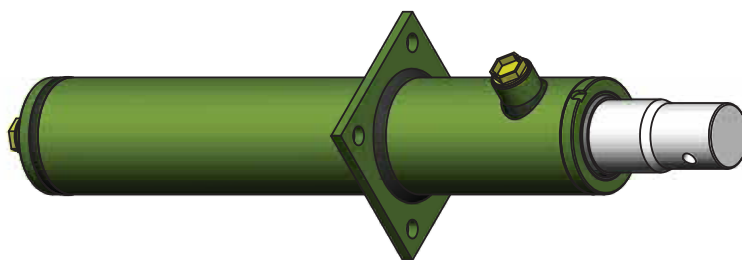

REF.	ØA	ØB	Z	E	G	I	J	K	ØL	M	PESO WEIGHT POIDS GEWICHT (kg)	FUERZA DE EMPUJE/PUSHING FORCE FORCE DE POUSÉE/DRUCKKRAFT 200BAR - (ton)
RAC5070550A	50	70	550	767	170	103	90	120	13	G1/2"	19,65	7,7
RAC6080650B	60	80	650	866	170	112	100	160	14	G1/2"	34,85	10
RAC7090650C	70	90	650	878	170	112	100	160	15	G3/4"	44,00	12,7

DISTRIBUIDOR

Spool valve / Distributeur / Verteiler

Distribuidor especial con gatillo para rachadoras / Special spool valve with automatic kick out feature
Distributeur spécial avec gâchette pour fendeuses / Spezialverteiler mit Auslöser für Spalter

Caudal nominal / Nominal flow / Débit nominal / Nenndurchfluss: 80 l/m
Presión max. / Max. pressure / Pression maximale / Maximaler Druck: P:250bar - T:10bar - A/B:300bar
CI80P81: Centro Cerrado - Closed center - Centre fermé - Mitte Geschlossen
CI80P81-RS: Centro Abierto - Open center - Centre ouvert - Mitte offen

REF.	MOD	P	A;B	T/N	PESO WEIGHT POIDS GEWICHT (kg)
CI80P81	Normal - Regular - Normale - Normal	G3/4	G1/2	G3/4	3,8
CI80P81-RS	Alta velocidad - High-speed - Grande Vitesse - Hohe geschwindigkeit	G3/4	G1/2	G3/4	3,8

